

Vacuum Cup Suspension Assemblies



Vacuum Pad Mounting Accessories



Adjustable Pad Slides

Adjustable pad slides are available in a variety of sizes to fit most crossarms. These sturdy aluminum slides feature a heavy plastic locking knob and dual clamping areas to keep pad attachments firmly locked in place. Stainless Steel brake pads are included to minimize marring of the crossarms while still allowing for easy adjustment.

Replacement Parts

Replacement parts for all vacuum cup and slide assemblies are available from stock. ANVER stocks a large number of suspension studs, springs, ball and stud assemblies, and other replacement components for our suspension assemblies. However, it is usually more economical and convenient to replace the entire assembly. Please consult factory for best option.

Available from stock:

- Ball Swivel Assemblies
- Replacement Springs
- Replacement Cups and Sealing Rings
- Hose and Hose Barbs
- Suspension Rods

Beams and Crossarms

Load beams and crossarms are also available in many sizes and styles to best suit your application. Crossarms are made from heavy duty carbon steel, then nickel plated for long life. Mounting holes allow attachment to either another main beam or directly to an existing system.

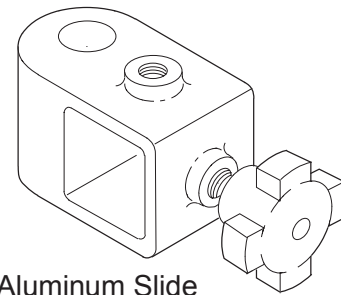
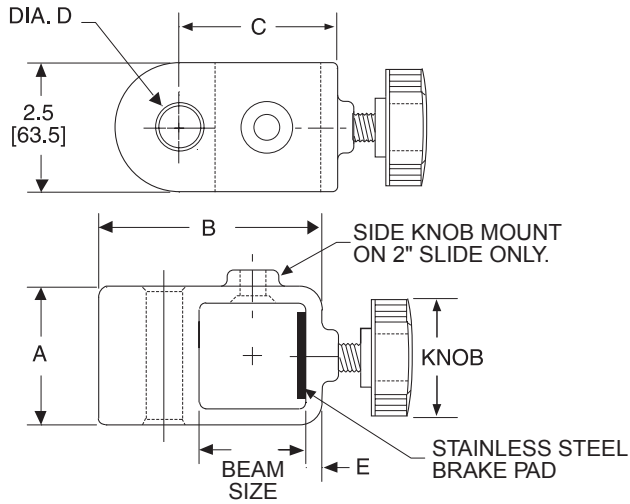

Aluminum Slide
with Stainless Steel
Brake Pad and Assembly

Vacuum Cup Suspension Assemblies



Adjustable Brackets for Various Suspension Rods

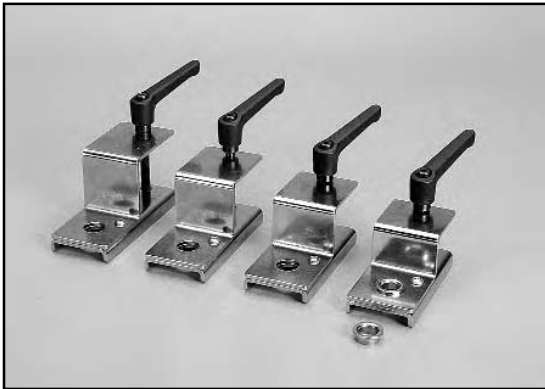

Adjustable brackets for various suspension rods are available in a variety of sizes to fit most crossarms.

Fits Steel Tubing Sizes 1 1/4", 1 1/2", 1 3/4" and 2".

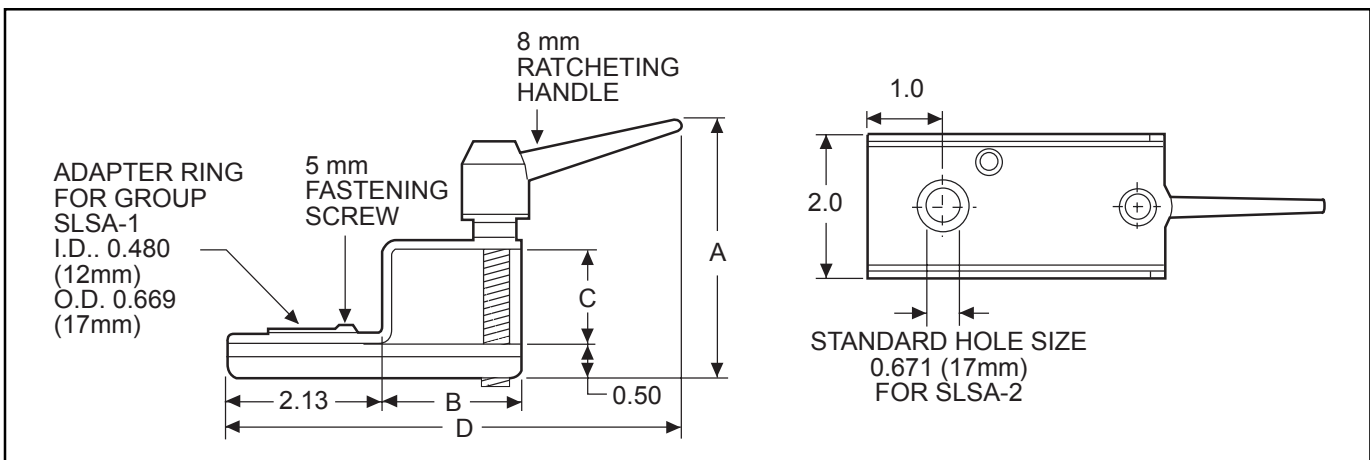

ANVER Item No.	Description	A in. (mm)	B in. (mm)	C in. (mm)	D in. (mm)	Fits Tubing Size in. (mm)
SBA-125	Slide Bracket Assembly, for 1-1/4" Beams	3.61 (91.7)	1.92 (48.8)	1.27 (32.3)	6.23 (158.2)	1.25 x 1.25 (31.75 x 31.75)
SBA-150	Slide Bracket Assembly, for 1-1/2" Beams	3.86 (98.0)	2.17 (55.1)	1.52 (38.6)	6.43 (163.3)	1.50 x 1.50 (38.1 x 38.1)
SBA-175	Slide Bracket Assembly, for 1-3/4" Beams	4.11 (104.4)	2.42 (61.5)	1.77 (45.0)	6.67 (169.4)	1.75 x 1.75 (44.5 x 44.5)
SBA-200	Slide Bracket Assembly, for 2" Beams	4.36 (110.7)	2.67 (67.8)	2.02 (51.3)	6.92 (175.8)	2.00 x 2.00 (50.8 x 50.8)



Adapter No.: 212-00-679
(Guide, Spacer for SLSA-1 Series)

Vacuum Cup Suspension Assemblies

SLSA-1 Series (M5-10/32 UNF Thread)



ANVER Vacuum Suction Cups can be mounted to most vacuum systems using Spring Loaded Suspension Assemblies. These are high quality, well finished and designed for high speed automation applications. Adjustable bulkhead fittings mount to almost any lifting frame while a variety of tube fittings are available to connect to the vacuum generating system. These unique mounting systems act as extensions while providing support while handling a load. Some of the advantages of Suspension Assemblies include:

- Suspensions reduce machine indexing when picking up material from a stack.
- They compensate for variations in object height and offer a soft touch attach.
- Shock and noise to an object and machine is minimized.
- Cup pressure is consistent on each pick up which increases the cups life.
- Suspensions can provide an easy way to interface the vacuum cup and vacuum lines to the machine tooling.

Our SLSA-1 Series connect to the vacuum system via M5, 10/32 UNF female threads. For 1/8" NPT male threads use our SLSA-2 series.

ANVER can adapt these vacuum cup suspensions to your particular needs with tube fittings, mini vacuum generators, sensing valves and custom adapters. Please contact our technical sales department for assistance.

Components	Rotating	Non-Rotating
Suspension Tube:	Nickel-Plated Tube	Stainless Steel
Springs:	Stainless Steel	Stainless Steel
Bulkhead Thread:	Nickel-Plated Brass	Nickel-Plated Brass
Panel Nuts:	Nickel-Plated Brass	Stainless Steel

ANVER Item No.	Connection Thread Size	Fitting Group	Travel in. (mm)	Height in. (mm)	Required Panel Hole Dia. in. (mm)	Max. Panel Thickness in. (mm)
SLSA-105NR Non-Rotating	M5 (female) 10/32 UNF	1 & 2	0.20 (5)	1.14 (29)	0.51 (13)	0.43 (11)
A-3350068 Rotating	M5 (female) 10/32 UNF	1 & 2	0.39 (10)	1.69 (43)	0.39 (10)	0.56 (14)
SLSA-110NR Non-Rotating	M5 (female) 10/32 UNF	1 & 2	0.39 (10)	1.54 (39)	0.51 (13)	0.43 (11)
SLSA-120NR Non-Rotating	M5 (female) 10/32 UNF	1 & 2	0.79 (20)	2.32 (59)	0.51 (13)	0.43 (11)
SLSA-130NR Non-Rotating	M5 (female) 10/32 UNF	1 & 2	1.18 (30)	3.11 (79)	0.51 (13)	0.43 (11)

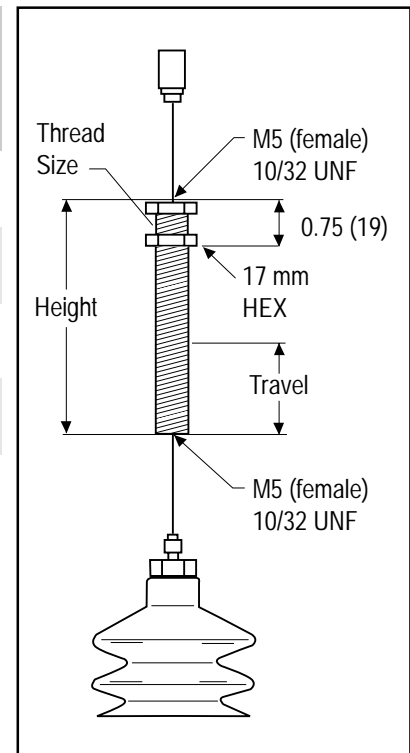

Vacuum Cup Suspension Assemblies



SLSA-2 Series (1/8" NPT Thread)



ANVER Vacuum Suction Cups can be mounted to most vacuum systems using Spring Loaded Suspension Assemblies. These are high quality, well finished and designed for high speed automation applications. Adjustable bulkhead fittings mount to almost any lifting frame while a variety of tube fittings are available to connect to the vacuum generating system. These unique mounting systems act as extensions while providing support while handling a load. Some of the advantages of Suspension Assemblies include:

- Suspensions reduce machine indexing when picking up material from a stack.
- They compensate for variations in object height and offer a soft touch attach.
- Shock and noise to an object and machine is minimized.
- Cup pressure is consistent on each pick up which increases the cups life.
- Suspensions can provide an easy way to interface the vacuum cup and vacuum lines to the machine tooling.

The SLSA-2 Series connects to the vacuum system via 1/8" NPT Male thread. For M5 Threads, see our SLSA-1 Series.

Materials:

Components	Rotating	Non-Rotating
Suspension Tube:	Nickel-Plated Brass	Nickel-Plated Steel
Springs:	Stainless Steel	Stainless Steel
Bulkhead Thread:	Nickel-Plated Brass	Stainless Steel
Panel Nuts:	Nickel-Plated Brass	Stainless Steel

ANVER can adapt these vacuum cup suspensions to your particular needs with tube fittings, mini vacuum generators, sensing valves and custom adapters. Please contact our technical sales department for assistance.

ANVER Item No.	Fitting Group	Travel in. (mm)	Height in. (mm)	Required Panel Hole Dia. in. (mm)	Max. Panel Thickness in. (mm)
SLSA-210NR	2 & 3	0.39 (10)	1.85 (47)	0.63 (16)	0.51 (13)
A-3350069	2 & 3	0.79 (20)	3.15 (80)	0.63 (16)	1.06 (27)
SLSA-230NR	2 & 3	1.18 (30)	3.45 (88)	0.63 (16)	0.51 (13)
SLSA-250NR	2 & 3	1.97 (50)	4.99 (127)	0.63 (16)	0.51 (13)
SLSA-270NR	2 & 3	2.76 (70)	6.61 (168)	0.63 (16)	0.51 (13)

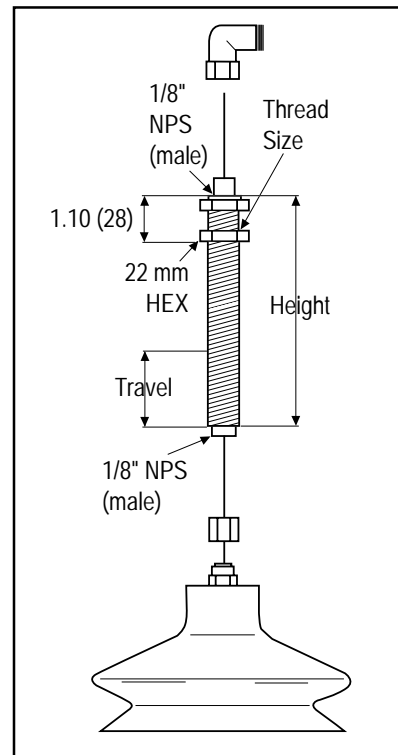

Vacuum Cup Suspension Assemblies



SLSA-3 Series



ANVER can adapt these vacuum cup suspensions to your particular needs with tube fittings, mini vacuum generators, sensing valves and custom adapters. Please contact our technical sales department for assistance.

ANVER Vacuum Suction Cups can be mounted to most vacuum systems using Spring Loaded Suspension Assemblies. These are high quality, well finished and designed for high speed automation applications. Adjustable bulkhead fittings mount to almost any lifting frame while a variety of tube fittings are available to connect to the vacuum generating system. These unique mounting systems act as extensions while providing support while handling a load. Some of the advantages of Suspension Assemblies include:

- Suspensions reduce machine indexing when picking up material from a stack.
- They compensate for variations in object height and offer a soft touch attach.
- Shock and noise to an object and machine is minimized.
- Cup pressure is consistent on each pick up which increases the cups life.
- Suspensions can provide an easy way to interface the vacuum cup and vacuum lines to the machine tooling.

Materials:

Suspension Rod:	Stainless Steel
Springs:	Stainless Steel
Bulkhead Thread:	Nickel-Plated Brass
Mounting Nuts:	Plated Steel

ANVER Item No.	Travel in. (mm)	Height in. (mm)
SLSA-330	1.94 (49)	4.00 (102)
SLSA-370	3.10 (79)	6.00 (152)
SLSA-399	4.75 (120)	8.00 (203)

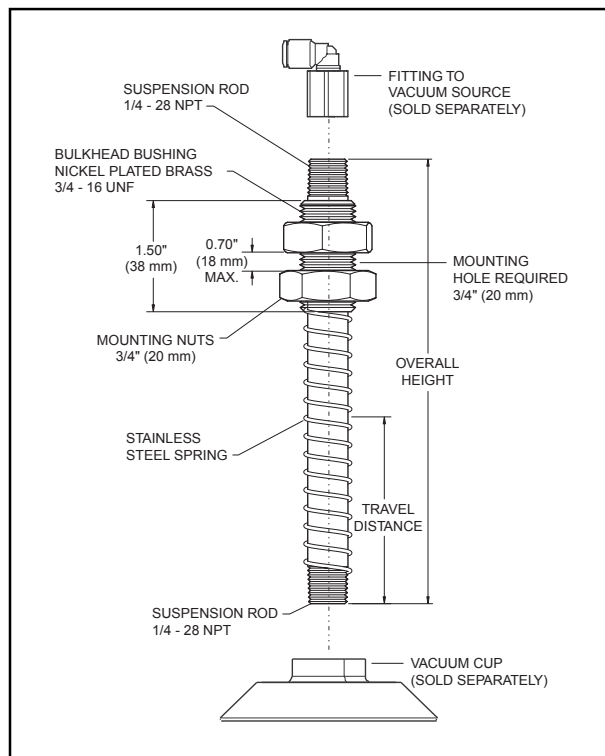

Vacuum Cup Suspension Assemblies



Rigid Cup and Slide Mount Assemblies



Also available for our small center port vacuum cups are spring loaded suspensions with adjustable pad slides. These assemblies are designed to be mounted on a load beam where vacuum cups need to be adjusted to varying load sizes. Three possible slides are available to fit common load beam and crossarm sizes. For use with VC Series and VP Series Vacuum Cups.

Features:

- Adjustable Slide Mounts
- For use with Small, Center Port Vacuum Cups (VC, VP Series)
- Designed for Rigid Cups

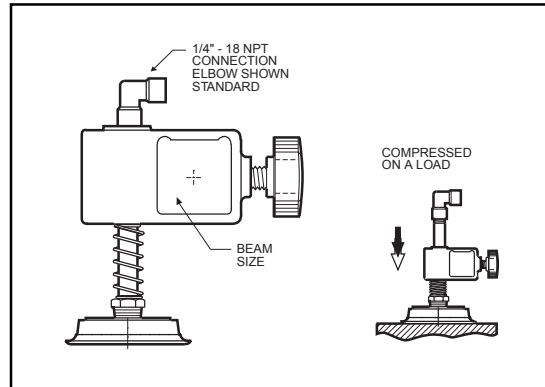

Vacuum Cup Suspension Assemblies



Rigid Cup and Slides with Side Vacuum Port



Rigid Suspension Assemblies are also available for our medium sized vacuum cups. Double spring suspensions and side vacuum ports make these assemblies perfect for virtually any material handling application. Adjustable slides are available in a variety of sizes making it easy to adapt to any system. Designed for Medium VC Series Vacuum Cups.

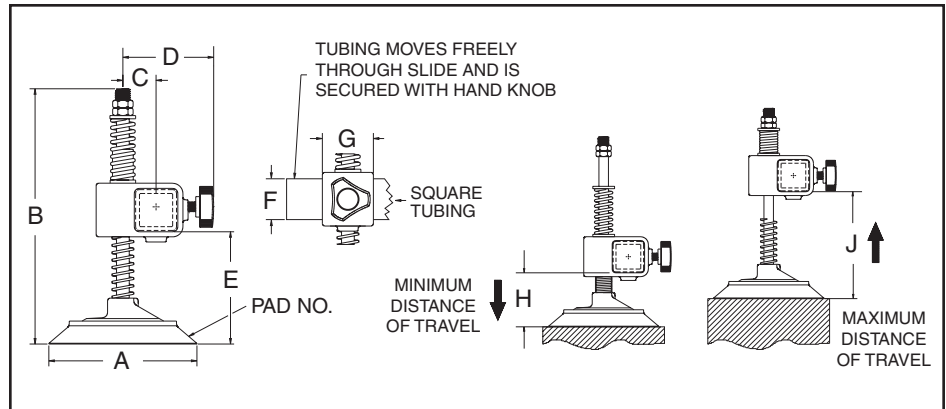

Features:

- Adjustable Slide Mounts
- For use with Medium, Side Port Vacuum Cups (VC Series)
- Designed for Rigid Cups

Susp. Model Number	A Cup Diameter in. (mm)	B in. (mm)	C in. (mm)	D in. (mm)	E in. (mm)	F Beam Size in. (mm)	G in. (mm)	H in. (mm)	J in. (mm)	Weight lb. (kg)	Capacity lb. (kg)*	Vacuum Pad Used
PS57R-NBR125	5.88 (149)	11.13 (283)	1.25 (32)	3.69 (94)	4.88 (124)	1.25 (32)	2.5 (64)	3.18 (81)	6.28 (160)	3.0 (1.4)	75 (34)	VC57
PS57R-NBR175	5.88 (149)	11.13 (283)	1.50 (38)	4.19 (106)	4.88 (124)	1.75 (44)	2.5 (64)	3.18 (81)	6.28 (160)	3.1 (1.4)	75 (34)	VC57
PS57R-NBR200	5.88 (149)	11.13 (283)	1.63 (41)	4.44 (113)	4.88 (124)	2.00 (51)	2.5 (64)	3.18 (81)	6.28 (160)	3.2 (1.5)	75 (34)	VC57
PS65R-NBR175	6.63 (168)	11.19 (284)	1.50 (38)	4.19 (106)	4.94 (125)	1.75 (44)	2.5 (64)	3.24 (82)	6.43 (163)	3.3 (1.5)	100 (45)	VC65
PS65R-NBR200	6.63 (168)	11.19 (284)	1.63 (41)	4.44 (113)	4.94 (125)	2.00 (51)	2.5 (64)	3.24 (82)	6.43 (163)	3.4 (1.5)	100 (45)	VC65
PS75R-NBR175	7.50 (191)	12.50 (318)	1.50 (38)	4.19 (106)	5.64 (143)	1.75 (44)	2.5 (64)	3.13 (80)	7.00 (178)	4.6 (2.1)	150 (68)	VC75
PS75R-NBR200	7.50 (191)	12.50 (318)	1.63 (41)	4.44 (113)	5.64 (143)	2.00 (51)	2.5 (64)	3.13 (80)	7.00 (178)	4.4 (2.0)	150 (68)	VC75
PS95R-NBR175	10.00 (254)	14.83 (377)	1.50 (38)	4.19 (106)	6.70 (170)	1.75 (44)	2.5 (64)	4.00 (102)	8.61 (219)	7.3 (3.3)	250 (113)	VC95R-2
PS95R-NBR200	10.00 (254)	14.83 (377)	1.63 (41)	4.44 (113)	6.70 (170)	2.00 (51)	2.5 (64)	4.00 (102)	8.61 (219)	7.2 (3.3)	250 (113)	VC95R-2
PS119R-NBR200	12.25 (311)	14.75 (3.75)	1.63 (41)	4.44 (113)	6.64 (169)	2.00 (51)	2.5 (64)	4.18 (106)	7.82 (199)	9.1 (4.1)	500 (227)	VC119R-2

* The cup capacities shown above are based on 24"Hg at sea level with a safety factor of two (2) in the horizontal (flat), and four (4) in the vertical (upright). Vertical Load Capacity is half of the listed Horizontal Load Capacities above. Rated Load Capacities are estimated; actual capacity will vary based on the load surface and the level of vacuum.

Vacuum Cup Suspension Assemblies



Ball Swivel Mounts with Side Vacuum Port



ANVER Ball Swivel Spring Suspension assemblies are the most versatile suspensions available. The ball and socket design provides up to 15° pivot in any direction. This unique feature enables the cups to compensate for wavy or slightly inclined loads. Designed for use with large size vacuum cups in the VC Series and VP Series.

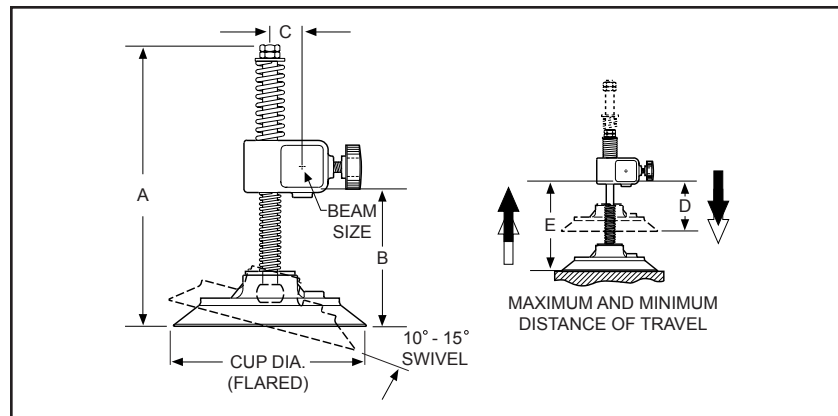

Features:

- Adjustable Slide Mounts
- For use with Medium, Side Port Vacuum Cups (VC, VP Series)
- Designed for Ball Swivel Cups

Susp. Assembly Number	Cup Dia. In. (mm)	A in. (mm)	B in. (mm)	C in. (mm)	D in. (mm)	E in. (mm)	Beam Size in. (mm)	Weight lb. (kg)	Capacity* lb. (kg)	Vacuum Pad Assembly
PS60S-NBR175	6.13 (156)	10.84 (275)	5.06 (129)	1.59 (40)	2.79 (71)	6.07 (154)	1.75 (44)	3.75 (1.7)	110 (50)	VP60-4
PS60S-NBR200	6.13 (156)	10.84 (275)	5.12 (130)	1.71 (43)	2.85 (72)	5.81 (148)	2.00 (51)	3.75 (1.7)	110 (50)	VP60-4
PS70S-NBR175	7.13 (181)	10.83 (275)	5.05 (128)	1.59 (40)	2.78 (71)	6.17 (157)	1.75 (44)	4.00 (1.8)	160 (73)	VP70-4
PS70S-NBR200	7.13 (181)	10.83 (275)	5.11 (130)	1.71 (43)	2.84 (72)	5.92 (150)	2.00 (51)	4.00 (1.8)	160 (73)	VP70-4
PS80S-NBR175	8.25 (210)	10.84 (275)	5.06 (129)	1.59 (40)	3.16 (80)	5.88 (149)	1.75 (44)	4.25 (1.9)	200 (91)	VP80-4
PS80S-NBR200	8.25 (210)	10.84 (275)	5.12 (130)	1.71 (43)	3.22 (82)	5.62 (143)	2.00 (51)	4.25 (1.9)	200 (91)	VP80-4
PS90S-NBR175	9.25 (235)	13.87 (352)	6.50 (165)	1.59 (40)	4.13 (105)	10.40 (264)	1.75 (44)	7.25 (3.3)	270 (123)	VP90-4
PS90S-NBR200	9.25 (235)	13.87 (352)	6.56 (167)	1.71 (43)	4.19 (106)	10.14 (258)	2.00 (51)	7.25 (3.3)	270 (123)	VP90-4
PS95S-NBR175	10.00 (254)	14.82 (376)	6.80 (173)	1.59 (40)	4.36 (111)	8.77 (223)	1.75 (44)	7.50 (3.4)	250 (113)	VC95R-4
PS95S-NBR200	10.00 (254)	14.82 (376)	6.86 (174)	1.71 (43)	4.42 (112)	8.52 (216)	2.00 (51)	7.50 (3.4)	250 (113)	VC95R-4
PS119S-NBR200	12.25 (311)	14.92 (379)	6.97 (177)	1.71 (43)	4.66 (118)	7.95 (202)	2.00 (51)	10.00 (4.6)	500 (228)	VC119-4
PS128S-NBR200	13.25 (337)	14.09 (358)	6.90 (175)	1.71 (43)	4.63 (118)	7.89 (200)	2.00 (51)	15.3 (5.9)	600 (272)	VP128S

* The cup capacities shown above are based on 24"Hg at sea level with a safety factor of two (2) in the horizontal (flat), and four (4) in the vertical (upright). Vertical Load Capacity is half of the listed Horizontal Load Capacities above. Rated Load Capacities are estimated; actual capacity will vary based on the load surface and the level of vacuum.

Vacuum Cup Suspension Assemblies



Quad-Mount Spring-Loaded Series



ANVER's larger vacuum cups and vacuum pads can be mounted using a quad spring suspension assembly. This mounting configuration ensures consistent attachment by allowing for adjustment to uneven or slightly tilted surfaces. A wide variety of slides are available for mounting to most standard load beam and crossarm sizes. For use with Large VC Series Cups and Large VP Series Pads.

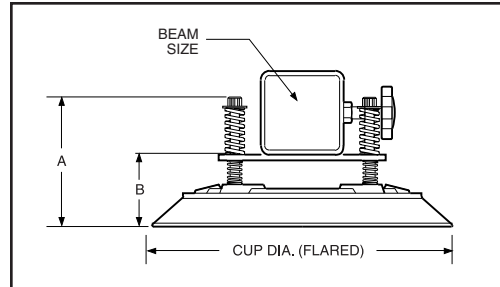

Suspension Assembly Number	Slide Size in. (mm)	Cup Dia. in. (mm)	A in. (mm)	B in. (mm)	Rated Load* lb (kg)	Vacuum Cup Number
PS95Q-NBR175	1.75 x 1.75 (44 x 44)	10.00 (254)	5.31 (135)	3.50 (89)	250 (113.6)	VC95Q
PS125Q-NBR200	2.00 x 2.00 (51 x 51)	13.00 (330)	5.50 (140)	3.28 (83)	500 (227.3)	VC125Q-2
PS125Q-NBR300	3.00 x 3.00 (76 x 76)	13.00 (330)	5.50 (140)	3.28 (83)	500 (227.3)	VC125Q-2
PS125Q-NBR360	3.00 x 6.00 (76 x 152)	13.25 (337)	6.30 (160)	4.44 (113)	600 (272.0)	VC125Q-2
PS90Q-NBR175	1.75 x 1.75 (44 x 44)	9.25 (235)	4.98 (127)	3.17 (81)	275 (125.0)	VP90Q
PS128Q-NBR200	2.00 x 2.00 (51 x 51)	13.25 (337)	5.80 (147)	3.28 (83)	600 (272.0)	VP128Q
PS128Q-NBR300	3.00 x 3.00 (76 x 76)	13.25 (337)	5.80 (147)	3.28 (83)	600 (272.0)	VP128Q
PS128Q-NBR360	3.00 x 6.00 (76 x 152)	13.25 (337)	6.30 (160)	4.44 (113)	600 (272.0)	VP128Q
PS158Q-NBR360	3.00 x 6.00 (76 x 152)	16.25 (413)	11.13 (284)	6.76 (172)	1200 (544)	VP158Q
PS158Q-NBR-570	5.00 x 7.00 (127 x 178)	16.25 (413)	12.13 (308)	7.69 (195)	1200 (544)	VP158Q



Vacuum Cup Suspension Assemblies

Clevis Mount Spring-Loaded Series



ANVER's larger vacuum cups and vacuum pads can be mounted using a quad spring suspension assembly. This mounting configuration ensures consistent attachment by allowing for adjustment to uneven or slightly tilted surfaces. A wide variety of slides are available for mounting to most standard load beam and crossarm sizes. For use with Large VC Series Cups and Large VP Series Pads.

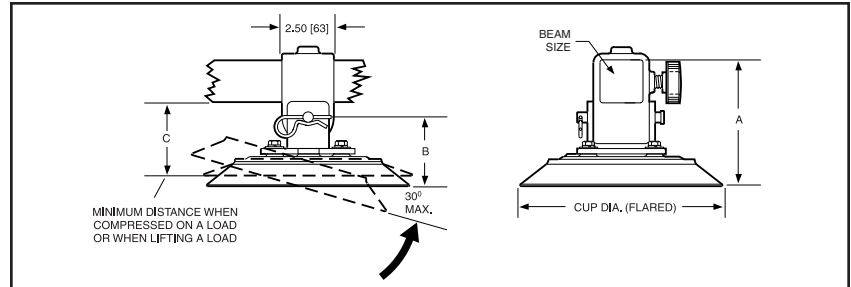

Suspension Assembly	Slide Size (Sq.) in. (mm)	Cup Dia. in. (mm)	A in. (mm)	B in. (mm)	C in. (mm)	Rated Load* lb (kg)	Vacuum Cup Number
PS95C-NBR175	1.75 (44)	10.00 (254)	5.81 (148)	3.31 (84)	2.64 (67)	250 (113.6)	VC95Q
PS95C-NBR200	2.00 (51)	10.00 (254)	6.06 (154)	3.31 (84)	2.64 (67)	250 (113.6)	VC95Q
PS95C-NBR300	3.00 (76)	10.00 (254)	8.11 (206)	3.31 (84)	4.45 (113)	250 (113.6)	VC95Q
PS125C-NBR200	2.00 (51)	13.00 (330)	6.78 (172)	4.03 (102)	3.38 (86)	500 (227.3)	VC125Q-2
PS125C-NBR300	3.00 (76)	13.00 (330)	8.84 (225)	4.03 (102)	5.19 (132)	500 (227.3)	VC125Q-2
PS60C-NBR200	2.00 (51)	6.13 (156)	5.75 (146)	3.00 (76)	3.38 (86)	110 (50)	VP60
PS70C-NBR200	2.00 (51)	7.13 (181)	5.75 (146)	3.00 (76)	3.38 (86)	160 (73)	VP70
PS80C-NBR200	2.00 (51)	8.25 (210)	8.25 (210)	3.06 (78)	3.38 (86)	220 (100)	VP80
PS90C-NBR175	1.75 (44)	9.25 (235)	5.48 (139)	2.98 (76)	2.50 (64)	275 (125.0)	VP90Q
PS90C-NBR200	2.00 (51)	9.25 (235)	5.73 (146)	2.98 (76)	2.50 (64)	275 (125.0)	VP90Q
PS90C-NBR300	3.00 (76)	9.25 (235)	7.78 (198)	2.98 (76)	4.31 (109)	275 (125.0)	VP90Q
PS128C-NBR200	2.00 (51)	13.25 (337)	5.67 (144)	2.92 (74)	3.25 (83)	600 (272.2)	VP128C
PS128C-NBR300	3.00 (76)	13.25 (337)	7.73 (196)	2.92 (74)	4.31 (109)	600 (272.2)	VP128C
PS158C-NBR300	3.00 (76)	16.25 (413)	5.56 (141)	3.94 (98)	9.00 (2.29)	1200 (544.0)	VP158C

* The cup capacities shown above are based on 24"Hg at sea level with a safety factor of two (2) in the horizontal (flat), and four (4) in the vertical (upright). Vertical Load Capacity is half of the listed Horizontal Load Capacities above. Rated Load Capacities are estimated; actual capacity will vary based on the load surface and the level of vacuum.